



BUCCHI
Fittings for
plastic pipes and systems



PRODOTTI PROFESSIONALI VERSATILI E KIT PER IL GIARDINAGGIO

VERSATILE PRODUCTS AND GARDENING KITS
PRODUITS POLYVALENTS ET KITS DE JARDINAGE



COSA CI RENDE DIFFERENTI

Grazie ad oltre quarant'anni di esperienza ci siamo specializzati nella progettazione, sviluppo e realizzazione di raccorderia, proponendo un'unicità di gamma per materiale PP Polipropilene e PA Nylon 66 e per grande versatilità. L'offerta molto variegata e con varie specificità, soddisfa le esigenze in vari settori dell'acqua e dei liquidi alimentari e aggressivi, specialmente dove sono utilizzati tubi flessibili.

LA MISSION

Ridefinire i confini e i contenuti del mercato dei raccordi e dei sistemi con raccordi e tubi per:

- la movimentazione dei fluidi e della relativa conduzione di calore;
- il trasporto di aria, gas di scarico e fumi;
- il trasporto di materiali granulari e polveri.

L'ambiente della Bucchi condivide questi valori che pongono la soddisfazione dei propri clienti come condizione essenziale del suo sviluppo e della sua sostenibilità. L'orgoglio di appartenenza e l'iniziativa sono il motore del nostro progresso e dei nostri successi. I prodotti sono versatili, di alta qualità e certificati da Enti internazionali. La produzione dei componenti è "100% Made in Italy".

Bucchi fornisce produttori e grossisti specializzati nei settori dell'industria, del giardinaggio, dell'agricoltura e dell'idro-termo-sanitario integrando la propria offerta con un dedicato servizio di Supporto Tecnico.

La continua evoluzione dei prodotti, la capacità di trovare soluzioni innovative e i controlli di qualità sono i punti cruciali per soddisfare i nostri clienti.

Ma Bucchi non è solo prodotti. Un servizio di consulenza tecnica, un'attenzione particolare ai clienti e alle loro esigenze personalizzate, contribuiscono ad aumentare il valore dell'offerta e a soddisfare le esigenze del mercato. Questa filosofia Bucchi non trascura la sostenibilità come strategia dell'azienda.



RACCORDI PORTAGOMMA con accoppiamento conico e filettatura mista GAS e profilo metrico, in poliammide 66 (PA) - (nylon) per tubi flessibili

HOSE NOZZLES (nylon)
polyammide PA 66 - with taper connections and mixed metric profile GAS threading for flexible hose

EMBOUS CANNELÉS
avec jonction conique et filetage mixte pas du GAZ et profil métrique, en polyamide 66 (PA) - (nylon) pour tuyaux flexibles

COMBINAZIONE RACCORDI PER ELETTROPOMPE DI SUPERFICIE E MOTOPOMPE

- Set of fittings for surface electric pumps and motor pumps
- Combinaison de raccords pour électropompes de surface et motopompes

IMMAGINE	DESCRIZIONE	CODICE	MISURE
	 <p>RACCORDO TRE PEZZI DIRITTO con accoppiamento conico estremità portagomma per tubo DN STRAIGHT THREE-PIECE FITTING with taper connection with male threaded end G1 with hose nozzle end for DN hoses</p>	0200044.000725	1"xDN 25 (1")
	 <p>RACCORD DROIT TROIS PIÈCES avec jonction conique extrémité embout cannelé pour tuyau DN</p>	0200044.000930	1" 1/4xDN 30 (1"3/16)
	 <p>PORTAGOMMA DIRITTO con O-ring in NBR STRAIGHT HOSE NOZZLE with NBR O-ring</p>	0200138.000725	1"xDN 25 (1")
	 <p>EMBOUS CANNELÉ DROIT avec joint torique en NBR</p>	0200138.000930	1" 1/4xDN 30 (1"3/16)
	 <p>RACCORDO TRE PEZZI CURVO a 90° con accoppiamento conico estremità portagomma per tubo DN 90° THREE-PIECE ELBOW FITTING with taper connection - with a male threaded end G1 with hose nozzle end for DN hoses</p>	0200046.000725	1"xDN 25 (1")
	 <p>RACCORD COUDÉ à 90° TROIS PIÈCES avec jonction conique extrémité embout cannelé pour tuyau DN</p>	0200046.000930	1" 1/4xDN 30 (1"3/16)

IMMAGINE	DESCRIZIONE	CODICE	MISURE
	 <p>VALVOLA DI FONDO "YURI" con attacchi femmina filettati G con guarnizione piana in NBR e filtro inox "YURI" FOOT VALVE with female threaded connection G with NBR flat seal and inox flite</p>	0202720.030707	1"
	 <p>VALVOLA DI FONDO con attacco femmina filettato G con guarnizione O-Ring in NBR FOOT VALVE with female threaded G with NBR O-Ring</p>	0200730.030909	1" 1/4

RACCORDO PORTAGOMMA TRE PEZZI PER LA GIUNZIONE DI DUE TUBI

- Three-piece hose connector for joining two pipes
- Raccord de tuyau en trois parties pour raccorder deux tuyaux

IMMAGINE	DESCRIZIONE	CODICE	MISURE
	 <p>RACCORDO PORTAGOMMA TRE PEZZI DIRITTO con accoppiamento conico per tubo DN STRAIGHT THREE-PIECE HOSE NOZZLE FITTING taper connection for DN hoses</p>	0200042.002020	20 (25/32")
	 <p>RACCORD EMBOUT CANNELÉ DROIT TROIS PIÈCES avec jonction conique pour tuyau DN</p>	0200042.002525	25 (1")
	 <p>RACCORD EMBOUT CANNELÉ DROIT TROIS PIÈCES avec jonction conique pour tuyau DN</p>	0200042.003030	30 (1"3/16)
	 <p>RACCORD EMBOUT CANNELÉ DROIT TROIS PIÈCES avec jonction conique pour tuyau DN</p>	0200042.003535	35 (1"3/8)
	 <p>RACCORD EMBOUT CANNELÉ DROIT TROIS PIÈCES avec jonction conique pour tuyau DN</p>	0200042.004040	40 (1"9/16)
	 <p>RACCORD EMBOUT CANNELÉ DROIT TROIS PIÈCES avec jonction conique pour tuyau DN</p>	0200042.005050	DN 50 (2")

VALVOLA DI FONDO E RACCORDO PORTAGOMMA per tubo flessibile, per kit d'aspirazione

HOSE NOZZLES (nylon)

polyamide PA 66 - with taper connections and mixed metric profile GAS threading for flexible hose

EMBOUITS CANNELÉS

avec jonction conique et filetage mixte pas du GAZ et profil métrique, en polyamide 66 (PA) - (nylon) pour tuyaux flexibles

IMMAGINE	DESCRIZIONE	CODICE	MISURE
	 Raccordo PORTAGOMMA DIRITTO (0400130) con O-ring in NBR STRAIGHT HOSE NOZZLE FITTING (0400130) with NBR O-ring RACCORD EMBOUT CANNELÉ DROIT (0400130) avec joint torique en NBR	0400138.050725	1"xDN 25 (1")
	 VALVOLA DI FONDO con raccordo portagomma per tubo DN, per KIT d'aspirazione FOOT VALVE with hose nozzle for DN hose, for suction KIT CLAPED DE PIED avec Émbout cannelé pour tuyau DN, pour kit d'aspiration	0401514.050725	DN 25 (1")

RACCORDI PORTAGOMMA a COMPRESSION BDFast® **BREVETTATI** (PN 10) in polipropilene (PP) per tubi flessibili

COMPRESSION HOSE NOZZLE BDFast® **PATENDED**

(PN10) of polipropilene (PP) for hoses

EMBOUITS CANNELÉS à COMPRESSION BDFast® **BREVETÉ**

(PN10) en polypropylène (PP) pour tuyaux flexibles

IMMAGINE	DESCRIZIONE	CODICE	MISURE
	 BDFast® PN10 - GIUNTO A GOMITO a 90° con un attacco per tubo DN e l'altro filettato maschio R BDFast® PN10 - 90° ELBOW with one connection for hose DN and one male thread BDFast® PN10 - COUDE À 90° avec extrémité pour tuyau DN et extrémité filetée mâle R	0102144.050725	1"xDN 25 (1")
	 BDFast® PN10 - GIUNTO MASCHIO DIRITTO con un attacco per tubo DN e l'altro filettato maschio R BDFast® PN10 - STRAIGHT MALE FITTING with one connection for hose DN and one male thread BDFast® Pn10 - RACCORD MÂLE DROIT avec extrémité pour tuyau DN et extrémité filetée mâle R	0102004.050725	1"xDN 25 (1")

IMMAGINE	DESCRIZIONE	CODICE	MISURE
	 BDFast® PN10 - GIUNTO MASCHIO DIRITTO con un attacco per tubo DN e l'altro filettato maschio R BDFast® PN10 - STRAIGHT MALE FITTING with one connection for hose DN and one male thread BDFast® Pn10 - RACCORD MÂLE DROIT avec extrémité pour tuyau DN et extrémité filetée mâle R	0102004.050725	1"xDN 25 (1")
	 VALVOLA DI FONDO "YURI" - Valvole antiriflusso di fondo o di ritegno con filettatura GAS "YURI" FOOT VALVE with female threaded connection G with NBR flat seal and inox filter CLAPET DE RETENUE "YURI" avec raccords femelles filetés G avec joint plat en NBR et bouchon	0202720.030307	1"

APPLICABILITÀ TUBO/RACCORDO

BDFast® utilizzabile con i seguenti tubi:



- Spiralo in PVC plastificato con spirale in PVC rigido antiurto. Superficie interna liscia e profilo ondulato, serie metrica e gas secondo la norma ISO 3994.

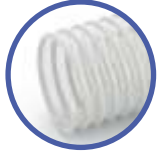

- Spiralo in PVC plastificato con spirale di rinforzo metallico. Superficie interna ed esterna liscia, serie metrica e gas.

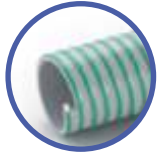

- Spiralo in PVC plastificato con rivestimento interno di Poliuretano e spirale di rinforzo in PVC rigido antiurto. Superficie interna liscia e profilo ondulato, serie metrica e gas secondo la norma ISO 3994.



- Spiralo in PVC plastificato con rivestimento interno di Poliuretano e spirale di rinforzo metallico. Superficie interna ed esterna liscia, serie metrica e gas.
- Monostrato in PVC plastificato. Superficie interna ed esterna liscia, serie metrica e gas.

APPLICABILITY HOSE/FITTING

BDFast® can be used with the following hoses:

- Spiralled in plasticized PVC with stiff shock-resistant PVC spiral. Smooth inner surface, corrugated profile, metric and gas lines according to ISO 3994 standards.

- Spiralled in plasticized PVC spiral with metal reinforcement. Smooth inner and outer surfaces. Metric and gas lines.

- Spiralled in plasticized PVC with polyurethane inner lining and stiff shock-resistant PVC reinforcement spiral. Smooth inner surface, corrugated profile. Metric and gas lines according to ISO 3994 standards.

- Spiralled in plasticized PVC with inner polyurethane lining and metal reinforcement spiral. Smooth inner and outer surfaces, metric and gas lines.

- Single layer, plasticized PVC. Smooth inner and outer surfaces. Metric and gas lines.

APPLICABILITÉ TUYAU/RACCORD

BDFast® peut être utilisé avec les tuyaux suivants:

- En PVC plastifié avec spirale en PVC rigide anti-choc. Surface intérieure lisse et profil ondulé, série métrique et gaz selon la norme ISO 3994.

- En PVC plastifié avec spirale de renfort en métal. Surface intérieure et extérieure lisse, série métrique et gaz.

- En PVC plastifié avec spirale de renfort en PVC rigide anti-choc et revêtement intérieur en polyuréthane. Surface intérieure lisse et profil ondulé, série métrique et gaz selon la norme ISO 3994

- En PVC plastifié avec spirale de renfort en métal et revêtement intérieur en polyuréthane. Surface intérieure et extérieure lisse, série métrique et gaz.

- En PVC plastifié monocouche. Surface intérieure et extérieure lisse, série métrique et gaz.

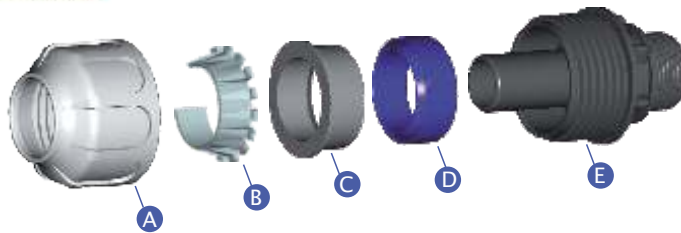

- A Ghiera di serraggio
- B Anello di graffaggio
- C Bussola premi-guarnizione
- D Guarnizione di tenuta
- E Corpo

ISTRUZIONI PER L'INSTALLAZIONE

Installation instructions
Instructions d'installation

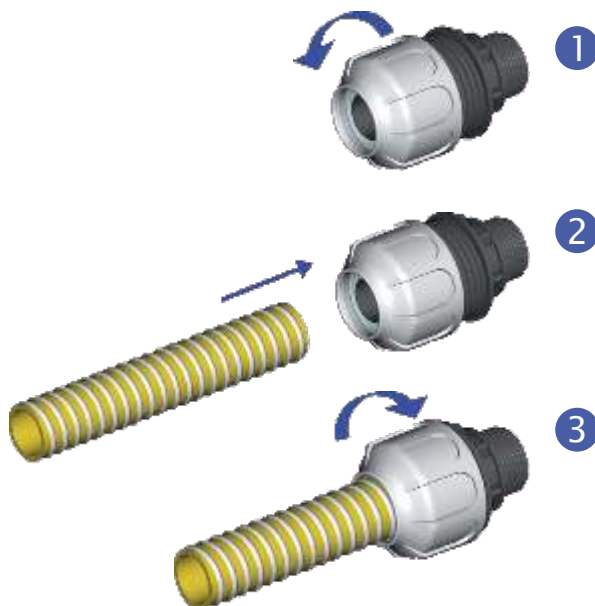

- 1) Allentare la ghiera senza svitarla completamente
- 2) Inserire il tubo nel raccordo fino al raggiungimento della battuta
- 3) Avvitare a mano la ghiera sul corpo facendo seguire per le dimensioni superiori a DN 25 mm un serraggio mediante le apposite chiavi **BDFast®**

- 1) Loosen the ring nut but do not unscrew it totally
- 2) Insert hose into fitting until it reaches the ledge
- 3) Screw the ring nut manually onto the body and in the case of sizes over DN 25 fasten with the suitable **BDFast®** wrench

- 1) Desserrer l'écrou sans le dévisser complètement
- 2) Insérer le tuyau dans le raccord jusqu'à l'arrêt
- 3) Serrer à la main l'écrou dans le corps et, pour des dimensions supérieures à DN 25 mm, serrer à l'aide des clés **BDFast®** correspondantes

RACCORDI COMPATIBILI GEKA® in poliammide (nylon) rinforzato con fibra di vetro per tubi flessibili

GEKA® COMPATIBLE FITTINGS

in polyamide (nylon) reinforced with glass fiber for flexible hoses

RACCORDS COMPATIBLES GEKA®

en polyamide (nylon) renforcé de fibre de verre pour tuyaux flexibles

IMMAGINE	DESCRIZIONE	CODICE	MISURE
	Raccordo rapido diritto per tubo DN Straight quick fitting for DN pipe Raccord rapide droit pour tuyau DN	0102570.474013	D40 x DN 13 (1/2")
		0102570.474016	D40 x DN 16 (5/8")
		0102570.474019	D40 x DN 19 (3/4")
		0102570.474025	D40 x DN 25 (1")
	Raccordo rapido calotta Quick coupling cup Bouchon d'accouplement rapide	0102573.474025	D40
	Raccordo rapido femmina Quick coupling F Raccord rapide F	0102572.474003	1/2"
		0102572.474005	3/4"
		0102572.474007	1"
	Raccordo rapido maschio Quick coupling M Raccord rapide M	0102571.474003	1/2"
		0102571.474005	3/4"
		0102571.474007	1"
	Guarnizione per raccordo rapido in NBR Gasket for quick coupling in NBR Joint pour raccord rapide en NBR	4002523.144040	D40
	Raccordo a Y FM FM Y fitting Raccord Y FM	0800687.030505	3/4" x 3/4" x 3/4"

COMBINAZIONE RACCORDI RAPIDI

Combination quick couplings
Raccords rapides combinés

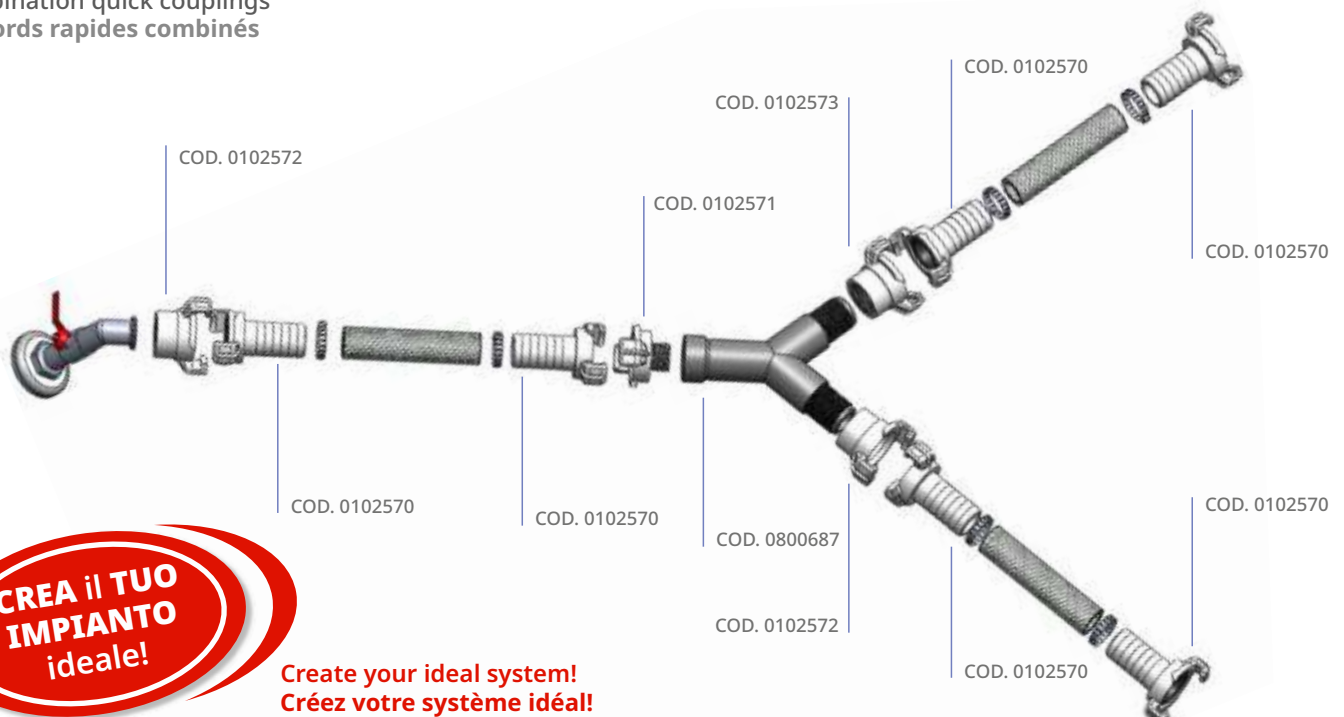

**CREA il TUO
IMPIANTO
ideale!**

**Create your ideal system!
Créez votre système idéal!**

RACCORDI PORTAGOMMA a COMPRESSIONE BDFast® compatibili GEKA® PN 16 in poliammide (nylon) PA in fibra di vetro per tubi flessibili

HOSE NOZZLES COMPRESSION BDFast® COMPATIBLE GEKA®

PN 16 in polyamide (nylon) PA fibre glass for flexible hoses

ÉMBOUS CANNELÉ À COMPRESSION BDFast® COMPATIBLES GEKA®

PN 16 en polyamide (nylon) PA en fibre de verre pour tuyaux flexibles

BDFast® COMPACT
LA MULTIFASCE INNOVATIVA



A



B

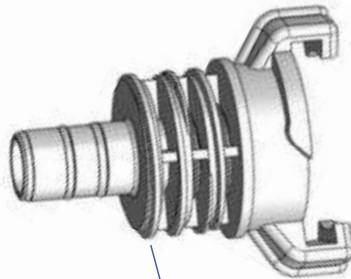

C

- A Ghiera di serraggio
- B Anello di graffaggio
- C Corpo

- A Nut
- B Split Ring
- C Body

- A Ecroue
- B Bague fendue
- C Corps

AVVERTENZA

BDFast® COMPACT è idoneo alla giunzione di tubi flessibili:



- In PVC plastificato con spirale in acciaio



- In poliuretano (PU) con spirale in PVC antiurto.

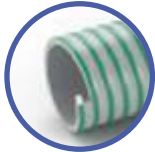

- In PVC con spirale in PVC rigido



- In PVC plastificato monostrato



- In PVC plastificato con rinforzo in fibra poliestere



- In PVC plastificato con inserto tessile tricoté



- In gomma con inserzioni di filati sintetici

NOTE

BDFast® COMPACT suitable for flexible pipe jioning made of:

- Plasticised PVC with steel ring

- Polyurethane (PU) with shockproof PVC ring

- PVC with rigid PVC ring

- Single-layer plasticised PVC

- Plasticised PVC with polyester fibre strengthening

- Plasticised PVC with tricoté textile insert

- Rubber with synthetic fabric inserts

AVERTISSEMENT

BDFast® COMPACT Adapté à la connexion de tuyaux flexibles:

- En PVC plastifié avec spirale en acier

- En polyuréthane (PU) avec spirale en PVC antichoc

- En PVC avec spirale en PVC rigide

- En PVC plastifié mono couche

- En PVC plastifié avec renfort en fibre polyester

- En PVC plastifié avec renforcement textile tricoté

- En caoutchouc avec armature de fils synthétiques

ISTRUZIONI PER L'INSTALLAZIONE

Installation instructions
Instructions d'installation



- 1) Allentare la ghiera senza svitarla completamente
- 2) Inserire il tubo nel raccordo fino al raggiungimento della battuta
- 3) Avvitare a mano la ghiera sul corpo

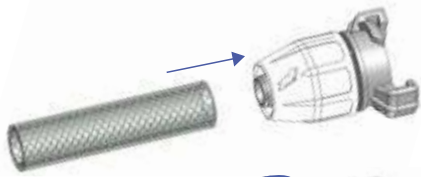

- 1) Loosen the ring nut but do not unscrew it totally
- 2) Insert hose into fitting until it reaches the ledge
- 3) Screw the ring nut manually onto the body

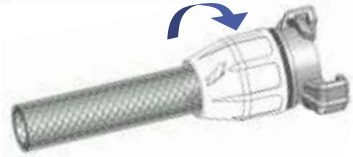

- 1) Desserrer l'écrou sans le dévisser complètement
- 2) Insérer le tuyau dans le raccord jusqu'à l'arrêt
- 3) Serrer à la main l'écrou dans le corps



IMMAGINE	DESCRIZIONE	CODICE	MISURE
	Raccordo rapido diretto per tubo DN Straight quick fitting for DN pipe	0102520.474013	D40 x DN 13 (1/2")
	Raccord rapide droit pour tuyau DN	0102520.474019	D40 x DN 19 (3/4")
	Raccordo rapido femmina Quick coupling F Raccord rapide F	0102572.474003	1/2"
		0102572.474005	3/4"
		0102572.474007	1"
	Raccordo rapido maschio Quick connection M Connexion rapide M	0102571.474003	1/2"
		0102571.474005	3/4"
		0102571.474007	1"
	Raccordo a Y FM FM Y fitting Raccord Y FM	0800687.030505	3/4" x 3/4" x 3/4"

COMBINAZIONE RACCORDI RAPIDI «compatibili GEKA®»

Combination quick couplings compatible GEKA®
Raccords rapides combinés compatibles GEKA®

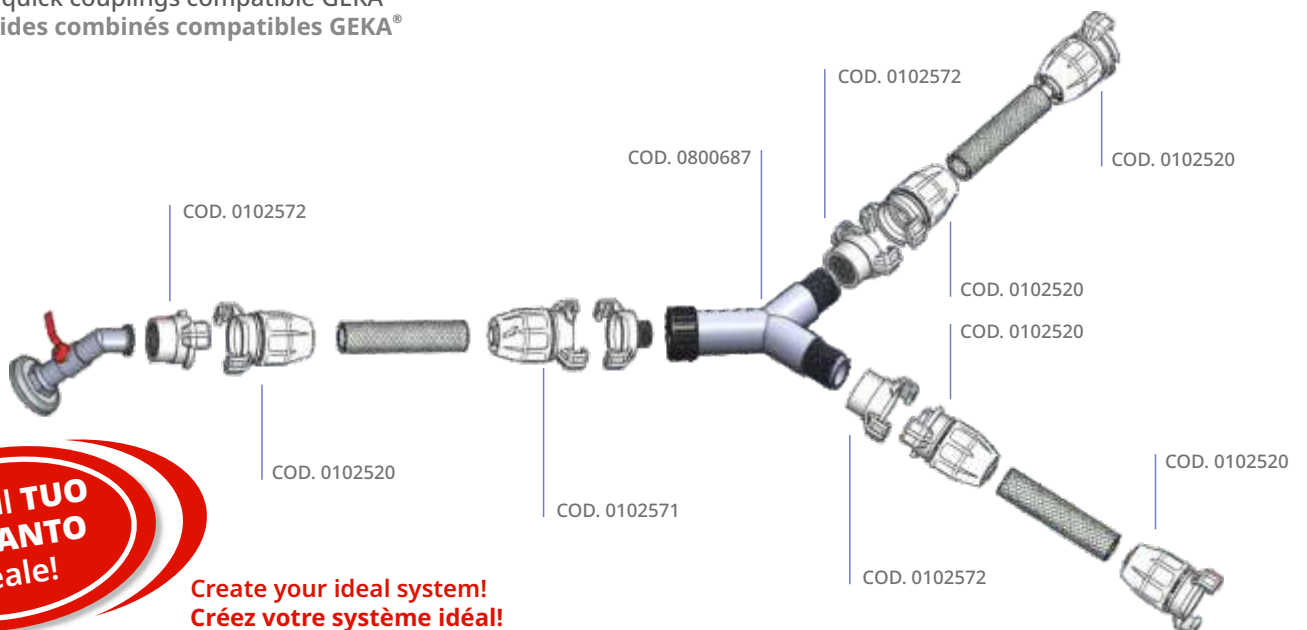

**CREA il TUO
IMPIANTO
ideale!**

**Create your ideal system!
Créez votre système idéal!**

RACCORDI PORTAGOMMA PER CISTERNE IBC PN 16 in poliammide (nylon) PA in fibra di vetro per tubi flessibili

HOSE FITTINGS FOR IBC TANKS

EMBOUT CANNELE POUR RÈSERVOIRS IBC

IMMAGINE	DESCRIZIONE	CODICE	MISURE
	 ADATTATORE FM estremità femmina filettata DIN 513 e G1 con guarnizioni in EPDM FM ADAPTER female threaded end DIN 513 and G with seals in EPDM ADAPTATEUR FM extrémité femelle fileté DIN 513 et G avec joints en EPDM	0102424.050566	560x6 - 3/4" M
	 VALVOLA A SFERA con attacchi: femmina filettato G e maschio filettato G1, O-Ring NBR BALL VALVE with connections: threaded female end G and threaded male end G1 with NBR O-ring VANNE À BILLE avec raccords: femelle fileté G et mâle fileté G1 avec joint torique en NBR	0200330.050505	3/4"
	 BDFast® COMPACT - RACCORDO DIRITTO F estremità femmina ghiera mobile filettata G con guarnizione piana in EPDM BDFast® COMPACT - STRAIGHT FITTING F female end threaded movable ring nut G with flat EPDM gasket	0102522.050513 0102522.050516	3/4"x DN 13 (1/2") 3/4" x DN 16 (5/8")
	 BDFast® COMPACT - RACCORD DROIT F extrémité femelle fileté écrou mobile G avec joint plat en EPDM	0102522.050520	3/4" x DN 20 (25/32")
	 BDFast® COMPACT - RACCORDO DIRITTO M estremità maschio filettata G1 con sede O-Ring BDFast® COMPACT - STRAIGHT FITTING M threaded male end G10 with O-Ring seat	0102530.050513 0102530.050516	3/4"x DN 13 (1/2") 3/4" x DN 16 (5/8")
	 BDFast® COMPACT - RACCORD DROIT M extrémité male fileté G1 avec logement pour joint torique	0102530.050520	3/4" x DN 20 (25/32")
	 Raccordo a Y FM FM Y fitting Raccord Y FM	0800687.030505	3/4" x 3/4" x 3/4"

COMBINAZIONE RACCORDI RAPIDI

Combination quick couplings
Raccords rapides combinés

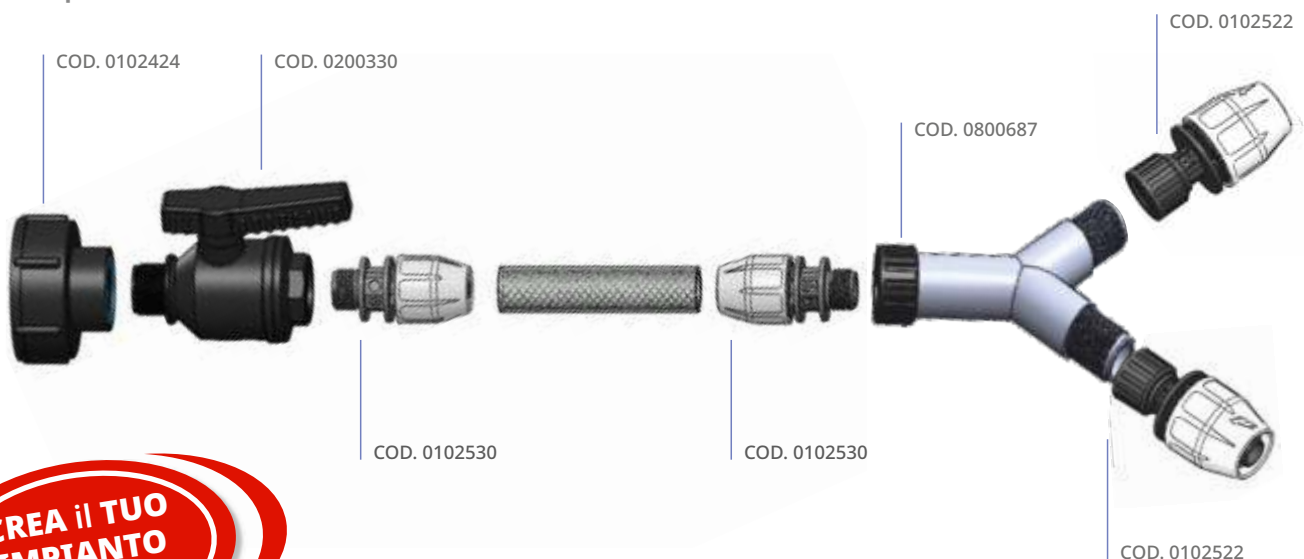

**CREA il TUO
IMPIANTO
ideale!**

**Create your ideal system!
Créez votre système idéal!**

RACCORDI PORTAGOMMA CON FILETTATURA GAS in poliammide 66 (PA) - (nylon) per tubi flessibili

L'ORIGINALE

HOSE FITTINGS WITH GAS THREAD

in polyamide 66 (PA) - (nylon) for flexible hose

THE ORIGINAL

EMBOUS CANNELÉS AVEC FILETAGE GAZ

en polyamide 66 (PA) - (nylon) pour tuyaux flexibles

L'ORIGINALE

RACCORDI PORTAGOMMA FEMMINA CON FILETTATURA GAS PER TUBI FLESSIBILI

Female hose nozzles with GAS thread for flexible hoses

Émbouts cannelé femelles avec filetage GAZ pour tuyaux flexibles

	DESCRIZIONE	CODICE	MISURE
	PORTAGOMMA DIRITTO FEMMINA DN e guarnizione in EPDM per tubi flessibili STRAIGHT FEMALE HOSE NOZZLE FITTING for DN hose and EPDM gasket RACCORD EMBOUT CANNELÉ DROIT FEMELLE avec joint plat en EPDM	0200120.000313	1/2" x DN 13 (1/2")
		0200120.000316	1/2" x DN 16 (5/8")
		0200120.000513	3/4" x DN 13 (1/2")
		0200120.000519	3/4" x DN 19 (3/4")
		0200120.000520	3/4" x DN 20 (25/32")
		0200120.000719	1" x DN 19 (3/4")
		0200120.000725	1" x DN 25 (1")
0200120.000932		1" 1/4 x DN 32 (1" 1/4)	
0200120.001138	1" 1/2 x DN 38 (1" 1/2)		
	DESCRIZIONE	CODICE	MISURE
	Portagomma diritto maschio per tubo DN Straight male hose nozzle for DN hose Embout cannelé droit male pour tuyau DN	0200130.000313	1/2" x DN 13 (1/2")
		0200130.000316	1/2" x DN 16 (5/8")
		0200130.000513	3/4" x DN 13 (1/2")
		0200130.000519	3/4" x DN 19 (3/4")
		0200130.000520	3/4" x DN 20 (25/32")
		0200130.000719	1" x DN 19 (3/4")
	DESCRIZIONE	CODICE	MISURE
	Raccordi portagomma tre pezzi per la giunzione di due tubi DN Three-piece hose connector for joining two DN pipes Raccord de tuyau en trois parties pour raccorder deux tuyaux DN	0200141.000313	DN 13 (1/2")
		0200141.000316	DN 16 (5/8")
		0200141.000519	DN 19 (3/4")
		0200141.000725	DN 25 (1")
	DESCRIZIONE	CODICE	MISURE
	Raccordo PORTAGOMMA DIRITTO MASCHIO con O-ring in NBR STRAIGHT MALE HOSE NOZZLE FITTING for hose DN with NBR O-Ring RACCORD EMBOUT CANNELÉ DROIT MÂLE pour tuyau DN avec O-Ring en NBR	0200138.000725	1" x DN 25 (1")
		0200138.000932	1/4" x DN 32 (1" 1/4)
		0200138.001138	1" 1/2 x DN 38 (1" 1/2)
	DESCRIZIONE	CODICE	MISURE
	PORTAGOMMA GOMITO A 90° FEMMINA con guarnizione piana in EPDM 90° ELBOW FEMALE HOSE NOZZLE for DN hose with EPDM flat gasket EMBOUT CANNELÉ COUDÉ À 90° FEMELLE pour tuyau DN avec joint plat en EPDM	0200121.000513	3/4" x DN 13 (1/2")
		0200121.000519	3/4 x DN 19 (3/4")
		0200121.000719	1" DN 19 (3/4")
		0200121.000725	1" x DN 25 (1")

MOLTI UTILIZZI

- 1) Per accoppiamenti sicuri, facili e veloci
- 2) Per prolungare le condotte e i sistemi flessibili
- 3) Per molteplici connessioni di tubi ed apparecchiature
- 4) Per il giardinaggio, acqua domestica, trattamento acqua, orticoltura, agricoltura

MANY USES

- 1) For safe, easy, fast couplings
- 2) To extend pipelines and flexible systems
- 3) For multiple connections of pipes to equipment
- 4) For gardening, domestic water, water treatment, horticulture, agriculture

NOMBREUSES UTILISATIONS

- 1) Pour des accouplements sûr, faciles et rapides
- 2) Pour prolonger les canalisations et les systèmes flexibles
- 3) Pour les raccordements multiples de tuyaux à l'équipement
- 4) Pour le jardinage, l'eau domestique, le traitement de l'eau, l'horticulture, l'agriculture

RACCORDI FILETTATI GAS E PORTAGOMMA in propilene (PP) per tubi flessibili

HOSE FITTINGS WITH GAS THREAD

in polyamide 66 (PA) - (nylon) for flexible hose

RACCORDS FILETÉS GAZ ET PORTE-FLEXIBLE

en polypropylene (PP) hose holder for tuyaux flexibles

COMBINAZIONE RACCORDI PER ELETTROPOMPE SOMMERGIBILI

Combination of fittings for submersible electric pumps

Émbouts cannelé femelles avec filetage GAZ pour tuyaux flexibles

IMMAGINE	DESCRIZIONE	CODICE	MISURE
	 <p>Gomito MF con portagomma gradinato per elettropompe sommergibili MF elbow with stepped hose connector for submersible electric pump Coude MF avec raccord de tuyau étagé pour électropompes submersibles</p>	0401515.055PNK00	1" 1/4 x DN 38 (1" 1/2) x 32 (1" 1/4) x 25 (1")
	 <p>Raccordo PORTAGOMMA GRADINATO DIRITTO con O-ring in NBR M STEPPED STRAIGHT HOSE NOZZLE FITTING with NBR O-ring RACCORD EMBOUT CANNELÉ EN GRADINS DROIT avec joint torique en NBR</p>	0401515.056PNK00	1" 1/2 x DN 38 (1" 1/2) x 32 (1" 1/4) x 25 (1")
 <p>Portagomma gradinato diritto F con ghiera fissa e guarnizione EPDM F STEPPED STRAIGHT HOSE NOZZLE FITTING for DN-DN(1) hoses - with female threaded end fixed ring nut G and EPDM flat gasket RACCORD EMBOUT CANNELÉ EN GRADINS DROIT pour tuyau DN-DN(1) - extrémité femelle écrou fixe fileté G avec joint plat en EPDM</p>	0400755.055OMK00	1" 1/4 x DN 35 (1" 3/8) x 30 (1" 3/16) x 25	
	0400801.055PN000	1" 1/4 x DN 38 (1" 1/2) x 32 (1" 1/4)	

RACCORDI RAPIDI A INNESTO

in polipropilene (PP) per serbatoi in PE o acciaio di diverse forme

QUICK FITTINGS

in polypropylene (PP) for tanks or steel of different shapes

RACCORDS RAPIDES

en polypropylène (PP) pour réservoirs en PE en acier de différentes formes

QJ - Quick Joints® è il RACCORDO RAPIDO a INNESTO per SERBATOIO in polipropilene che viene sviluppato come la nuova generazione dei raccordi passaparete.
Con l'utilizzo di QJ non è necessaria l'entrata all'interno del serbatoio. **BREVETTATI**

QJ - Quick Joints® is the QUICK COUPLING FITTING to GRAFT for polypropylene TANK which is being developed as the next generation of bulkhead fittings. With the use of QJ it is not necessary to enter the tank. **PATENDED**

QJ - Quick Joints® Rapide se joint est RACCORD QUICK à GREFFE pour Polypropylène TANK qui est développé comme la prochaine génération de raccords de cloison. Avec l'utilisation de QJ, il n'est pas nécessaire d'entrer dans le réservoir. **BREVETÉ**

IMMAGINE	DESCRIZIONE	CODICE	MISURE
	 <p>RACCORDO RAPIDO a INNESTO per SERBATOIO RIDOTTO MF in PP estremità maschio filettata munita di GUARNIZIONE in EPDM - ANELLO piano rigido in PP, COLLARE di serraggio (nero) - filettatura femmina ridotta QUICK PUSH-IN FITTING MF REDUCED for TANK in PP male threaded end equipped with EPDM, GASKET - rigid flat RING in PP, clamping COLLAR (black) - reduced female threaded end RACCORD RAPIDE pour RESERVOIR REDUIT MF en PP extrémité male fileté dotée de JOINT en EPDM - ANNEAU plat rigide en PP, COLLIER de serrage (noir) - réduite femelle fileté</p>	0402820.050705/E	1" x 3/4"

RACCORDO ESPLOSO

Fitting exploded view
Composants du raccord

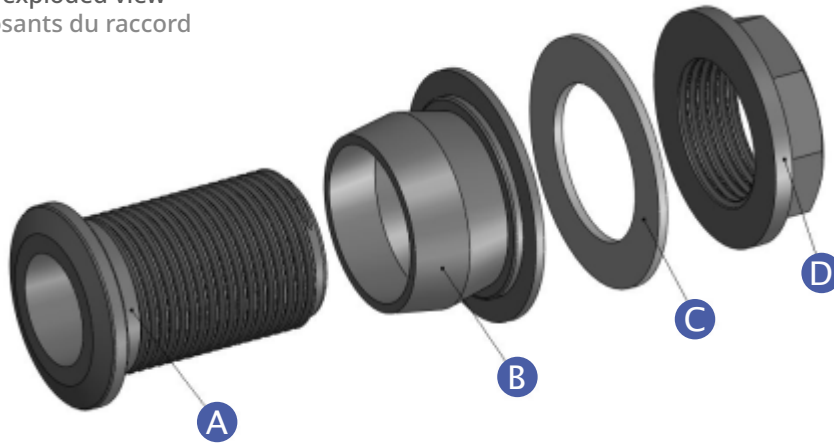

- A** Corpo filettato
- B** Guarnizione
- C** Rondella
- D** Ghiera

- A** Threaded body
- B** Gasket
- C** Washer
- D** Ring nut

- A** Corps de couplage fileté
- B** Joint
- C** Rondelle
- D** Virole

- Forare il serbatoio con presa a tazza

- Drill the tank with cut cutter

- Percer le réservoir avec un cutter



- Avvitare il raccordo sul serbatoio a mano o con avvitatore

- Screw the fitting on the tank by hand or with a drill

- Visse le reserved sur le réservoir à la main ou avec une perceuse



- Raccordo installato

- Fitting installed

- Raccord installé



IMMAGINE

DESCRIZIONE

CODICE

MISURE



ATTACCO PER SERBATOIO RIDOTTO MASCHIO-FEMMINA munito di collare di serraggio e guarnizione piana in EPDM

REDUCED MALE-FEMALE- TANK ADAPTOR with clamping collar and EPDM flat gasket

0400328.050705

1" x 3/4"

REDUCED MALE-FEMALE- TANK ADAPTOR with clamping collar and EPDM flat gasket

0400328.050907

1" 1/4 x 1"

ESEMPI APPLICATIVI

Application examples
Exemples d'applications



COMBINAZIONI DI RACCORDI E VALVOLE per serbatoi IBC

FITTINGS AND VALVE COMBINATION
for IBC tanks

RACCORD ET VANNE COMBINÉS
pour réservoirs IBC

IMMAGINE	DESCRIZIONE	CODICE	MISURE
	ADATTATORE FM estremità femmina filettata DIN 513 ed estremità maschio filettata GAS FM ADAPTER DIN 513 threaded female end and GAS male threaded end	0102424.050566	S60x6 - 3/4" M
	ADAPTATEUR FM DIN 513 bout femelle fileté et bout fileté mâle GAZ	0102424.050766	S60x6 - 1" M
	ADATTATORE FF estremità femmina filettate DIN 516 e GAS FF ADAPTER DIN 513 and GAS female threaded	0102454.050566	S60x6 3/4" F
	ADAPTEUR FF DIN 513 et GAZ bout femelle fileté	0102444.050766	S60x6 1" F
	VALVOLA A SFERA con attacchi: filetti GAS maschio e femmina BALL VALVE with connections: threaded female end and threaded male end with NBR O-ring	0200330.050505	3/4"
	VANNE À BILLE avec raccords: femelle fileté et mâle fileté avec joint torique en NBR	0200330.050707	1"
	Joint en EPDM EPDM flat gasket	0200125.160505	3/4"
	Joint en EPDM	0200125.160707	1"
	Calotta estremità filettata femmina CAP with female threaded end	0400180.050505	3/4"
	BOUCHON extrémité femelle fileté	0400180.050707	1"

COMBINAZIONE RACCORDI

Combination couplings
Raccords combinés

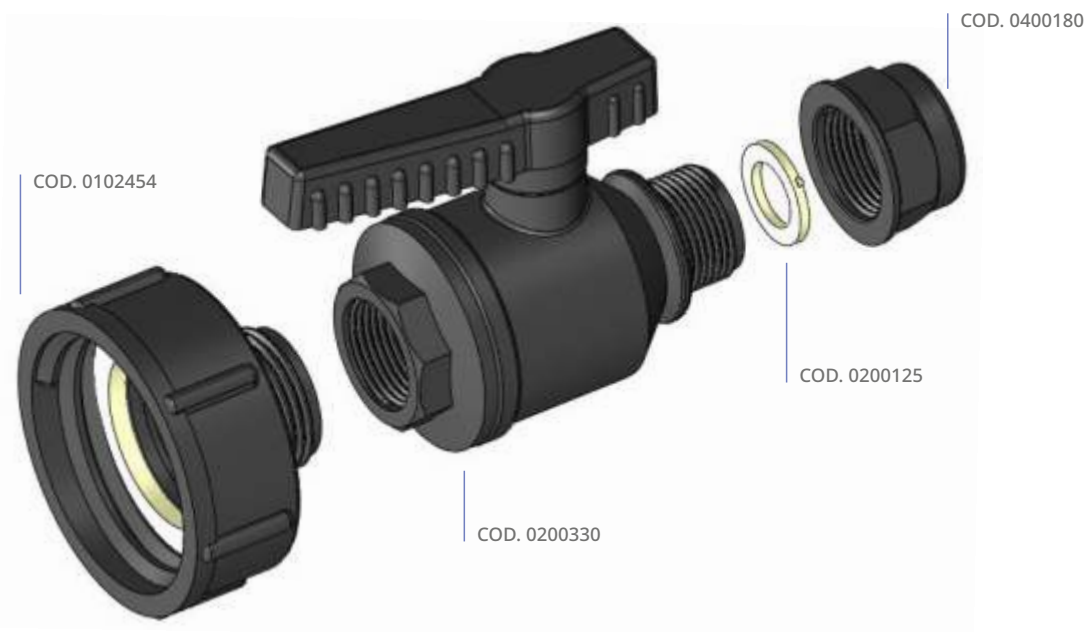

Create your ideal system!
Créez votre système idéal!

COMBINAZIONI DI RACCORDI E VALVOLE per serbatoi IBC

QUICK FITTINGS AND VALVE COMBINATION for IBC tanks

RACCORD RAPIDES ET VANNE COMBINÉS pour réservoirs IBC

IMMAGINE	DESCRIZIONE	CODICE	MISURE
	 <p>KIT passaparete per IBC: attacco rapido per serbatoio QJ® con innesto dall'esterno, valvola e giunto portagomma a compressione BDFast®.</p> <p>IBC tank adapter: quick coupling fitting (outside installation), valve and compression hose nozzle</p> <p>KIT passe-parois pour IBC: raccord rapide pour réservoir QJ® avec insertion de l'extérieur, vanne et raccord à compression BDFast® pour tuyau</p>	0101673.054K0000	Ø 25 mm

IMMAGINE	DESCRIZIONE	CODICE	MISURE
	 <p>KIT passaparete per IBC: attacco rapido per serbatoio QJ® con innesto dall'esterno, valvola, portagomma e calotta</p> <p>IBC tank adapter: quick coupling fitting (outside installation), valve, hose nozzle and cap</p> <p>KIT passe-parois pour IBC: raccord rapide pour réservoir QJ® avec insertion de l'extérieur, vanne, raccord pour tuyau et calotte</p>	0101674.054M0000	Ø 30 mm





BUCCHI 
Fittings for
plastic pipes and systems

BUCCHI S.r.l.

Via Bonsi, 57 - 48022 Lugo - Ravenna - Italia

Tel. +39 0545 901001 r.a. - Fax +39 0545 32232

bucchi@bucchi.it - www.bucchi.it